

TECO



# F510

Fan & Pump Drive

IP 20 / NEMA 1  
IP 55 / NEMA 12



# F510

## Mechanical Features

F510 realizes modular design, not only for applications of high protection level, but also for maintaining equipment inclusive of Hot plug display, communication card, removable fan, and etc...

## IP55 Water and Dust Protection Design

Teco launches the all new drives for fan and pump control which meet protection level-IP55 to provide various options for harsh environment.

## Enclosure



IP20



IP55 / NEMA12

## Hand/Auto/Off

Hand/Auto selection is a very convenient function when system failure, test and inspection. F510 provides friendly user interface of Hand/Auto selection. To get this function by using optional HOA digital operator.

LED / LCD Keypad



HAND / AUTO / OFF



Easy assembly and hot plug digital keypad



Quick install fan for maintaining



Easy assembly terminal cover, saving the time of installation



F510  
TECO

**WARNING**  
Risk of electrical shock, shut off main power and wait for 5 minutes before servicing.  
**CAUTION**  
Hot surface. Risk of burn.  
See manual before operation.



## Pump Cascade Control

- Possess constant pressure control technology.
- Provide quick parameter setting, favorable for most of water supply applications.
- Pump Cascade Control via optional pump card.

1 to 8 pump card is available for a larger water supply and constant pressure applications. It is sophisticated in water supply industry by built-in PID controller and simple PLC of the advantages of drive.

F510 series provides variable frequency power to realize the continuously variable speed of pump, and keep the pressure stable by built-in PID controller. 1 to 8 pump option card can control with up to 8 pumps.



*1 PUMP Card  
to 8*

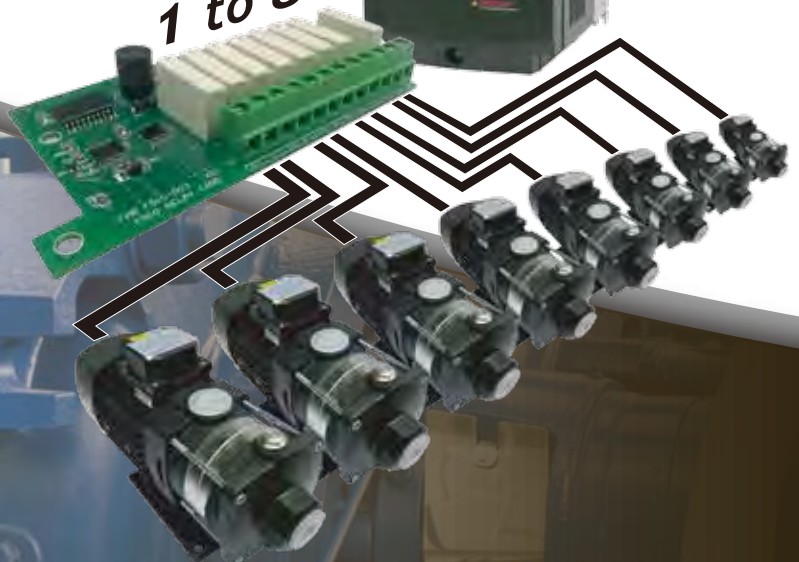

# F510

Energy Efficient  
Pump Control



## Excellent Pump Control

Built-in multi-pump control mode.

According to the load of water supply system, use intelligent control to coordinate pumps. It distributes running hours evenly across master and slave pumps to increase system efficiency and extend the life of drive.



### Blockage Inspection

F510 can detect clog of pump and give alarm to prevent overload pressure to damage pipes.

### Sleep Mode

Sleep mode saves energy by detecting when flow is low or zero. It can stop system to extend the life of drive.

### Dry Pump Protection

F510 can evaluate the system pressure and detect pump running dry. It will shut off pump immediately to protect it from heat and friction damage.

# F510

## High Efficient Fan Control

With hardware safe torque off function and fire override mode for emergency.



## Fire Override Mode

This feature is crucial for ensuring smoke extraction from building by air conditioner or fume extractor. In Fire mode, the drive will be used in full load operation as either forward or reverse direction and ignore all software protection until trigger hardware protection or drive damaged, to achieve the requirements of smoke extraction and reduce smoke damage to human as possible.

## Skip Frequency

F510 can avoid resonance by quick parameter setting. Preventing mechanical damage to system and fans.

# Hardware Safe Torque Off Function

Built-in high reliable hardware circuit for safe torque off.

The operator can use the safety switch to protect staff or system in emergency timely.

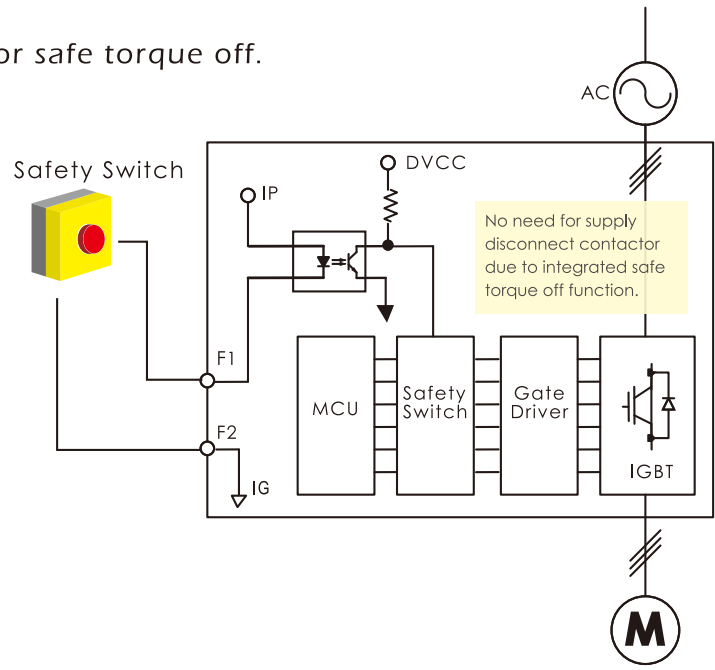

# F510

## Communication Network Protocol

Advanced network functions for building automation inclusive of BACnet , Metasys N2 and Modbus.

F510 can reduce the cost of installing automatic central air conditioning system.



**METASYS** is a communication protocol developed by Johnson Controls Inc. It is according to the actual needs of user and manager in building. Metasys N2 is easy to install, use, and adjust. System maintenance becomes very convenient. Metasys N2 may also collect, record, preserve and manage important message and data of the system, to achieve the best automatic management and energy saving effect.







has become a defacto standard communication protocol, and it is now amongst the most commonly available means of connecting industrial electronic devices.



is a communications protocol for building automation and control networks. It is an ASHRAE, ANSI, and ISO standard protocol. BACnet was designed to allow communication of building automation and control systems for applications such as heating, ventilating, and air-conditioning control, lighting control, access control, and fire detection systems and their associated equipment. The BACnet protocol provides mechanisms for computerized building automation devices to exchange information, regardless of the particular building service they perform.



## Permanent-Magnet Motor Control Technology

Permanent-magnet motor control technology avoids energy wasting. PM motor with high efficiency rises importance for present trend of energy saving and emission reduction.

## Conformity To Global Standards

Conformity to RoHS directive and international recognized certification.

## RoHS

UL/cUL approval and CE certification.



## Ultra Low Motor Noise

Soft PWM technology reduces common-mode voltage to restrain EMI and make motor noise down significantly.

Traditional PWM modulation method

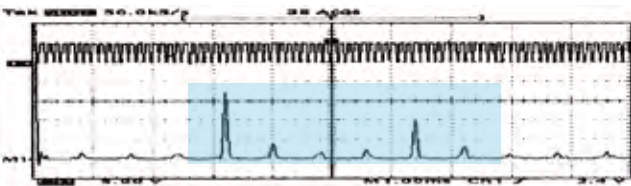

Unique Soft PWM modulation technology lowers the audible motor noise for quieter industrial environment.

Soft PWM modulation method

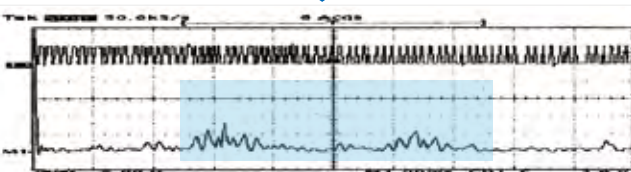

# F510

## Saving Energy

The issue of saving energy and emission reduction become popular in recent years. The importance of relative technologies grows as time. F510 provides various technologies of saving energy.

## RTC Function / Simple PLC

Automatic control has been mainstream. It is not only saving human resource cost ,but also handling system load more efficiently. To adjust load to avoid unnecessary expense by built-in simple PLC with Real Time Clock Function. It can modulate load easily to achieve the purpose of daylight saving.

※ The RTC fuction only for LCD keypad.

## Automatic Energy Saving Function

F510 can adjust to the optimum output voltage, and lower the output current of the drive according to the load automatically. The output power changes by the load proportion. In light duty, the AES has highest efficiency.



## BASIC SPECIFICATIONS

### 220V Class

Inverter Capacity (HP)		5	7.5	10	15	20	25	30	40	50	60	75	100	125	150	175	
Output Rated	Rated Output Capacity (KVA)	5.5	8	11.4	15.2	21.3	26.2	30	41.9	52.5	64.3	76.2	95.2	119	152	171	
	Rated Output Current (A)	14.5	22	30	42	56	69	79	110	138	169	200	250	312	400	450	
	Maximum Applicable Motor	(HP)	5	7.5	10	15	20	25	30	40	50	60	75	100	125	150	175
		(KW)	3.7	5.5	7.5	11	15	18.5	22	30	37	45	55	75	90	110	130
	Maximum Output Voltage (V)	Three Phase, 200V~240V															
Maximum Output Frequency (Hz)	Based on parameter setting 0.1~400.0 Hz																
Input Power	Rated Voltage, Frequency	Three Phase, 200V ~ 240V, 50/60Hz															
	Allowable Voltage Fluctuation	-15% ~ +10%															
	Allowable Frequency Fluctuation	±5%															

### 440V Class

Inverter Capacity (HP)		5	7.5	10	15	20	25	30	40	50	60	75	100	125	150	175	215	250	300	375	425	535	670	800	
Output Rated	Rated Output Capacity (KVA)	7	8.4	13	18	24	28.9	34	41	55	67	78	110	125	158	190	225	250	331	392	445	525	640	731	
	Rated Output Current (A)	9.2	12.1	18	23	31	38	44	54	73	88	103	145	168	208	250	296	328	435	515	585	690	840	960	
	Maximum Applicable Motor	(HP)	5	7.5	10	15	20	25	30	40	50	60	75	100	125	150	175	215	250	300	375	425	535	670	800
		(KW)	4	5.5	7.5	11	15	18.5	22	30	37	45	55	75	90	110	132	160	185	220	280	315	400	500	600
	Maximum Output Voltage (V)	Three Phase, 380V~480V																							
Maximum Output Frequency (Hz)	Based on parameter setting 0.1~400.0Hz																								
Input Power	Rated Voltage, Frequency	Three Phase, 380V ~ 480V, 50/60Hz																							
	Allowable Voltage Fluctuation	-15% ~ +10%																							
	Allowable Frequency Fluctuation	±5%																							

Notes :

1. Based on the standard 4-pole induction motor. Selecting inverter must have a higher output current rating than motor.
2. IP55 models is only for 440V class with LCD display, the capacity is from 5 to 100HP.
3. The maximum output frequency of each control mode is different, please refer to user manual for more details.

## GENERAL SPECIFICATIONS

Control Characteristics	Display	LED keypad with 5-digits seven-segment display or LCD keypad (HOA LCD keypad option)all LCD keypad with parameter copy function
	Control Modes	V/F, SLV, PMSLV with Space Vector PWM Mode
	Output Frequency	0.1Hz ~ 400.0Hz
	Frequency Accuracy	Digital references : $\pm 0.01\%$ (-10 ~ +40°C), Analog references : $\pm 0.1\%$ (25°C $\pm 10^\circ\text{C}$ )
	Speed Control Accuracy	$\pm 0.5\%$ (Sensorless Vector Control Mode) <sup>1</sup>
	Frequency Setting Resolution	Digital references : 0.01Hz, Analog references : 0.06Hz/60Hz
	Output Frequency Resolution	0.01Hz
	Overload Tolerance	120% /1 min
	Frequency Setting Signal	DC 0 ~ +10V / -10V~+10V or 4 ~ 20mA
	Acceleration / Deceleration Time	0.0 ~ 6000.0 second (separately set acceleration and deceleration time )
	Voltage / Frequency Characteristics	Can arbitrarily set V / F curve based on parameters
	Braking Torque	About 20%
	Main Control Functions	Auto Tuning, Soft-PWM, Over-Voltage Protection, Dynamic Braking, Speed Search, Momentary Power Loss Restart, 2 Sets of PID Control, Slide Difference Compensation, RS-485 Communication Standard, Simple PLC Function, 2 Sets of Analog Output, Safety Switch
Other Functions	Records of Power On and Operation Time, 4 Fault History Records and Latest Fault Record State, Energy-Saving Function, Phase Loss protection, Smart Braking, DC Braking, Dwell, S Curve Acceleration and Deceleration, Up / Down Operation, Modbus, BACNet MS/TP, and Metasys N2 Communication Protocol, Display of Multi- Engineering Unit, Local / Remote Switch, SINK / SOURCE Input Selection, User Parameter Settings	
Protection Functions	Stall Protection	Current level can be set (in acceleration or constant speed, it can be set separately. In deceleration, it can be set with or without protection)
	Over Current (OC) and Output Short-circuit (SC) Protection	It stops when the current exceeds 160% of the inverter rated current
	Inverter Overload Protection (OL2)	Inverter will be stopped when the output higher than 120% rated current for 1 min, Carrier frequency is 2~4KHZ <sup>2</sup>
	Motor Overload Protection (OL1)	Electrical overload protection curve
	Over Voltage Protection (OV)	If the main circuit DC voltage is over 410V (220V class) / 820V (440V class), the motor stops running
	Under Voltage Protection (UV)	If the main circuit DC voltage is under 190V (220V class) / 380V (440V class), the motor stops running
	Momentary Power Loss Restart	Power loss exceeds 15ms. You can set the function of momentary power loss restart up to 2sec
	Overheat Protection(OH)	Thermistor sensor on heatsink
	Ground Fault Protection(GF)	Protection by current detection circuit
	Charge Indicator	When main circuit DC voltage $\geq 50\text{V}$ , the CHARGE LED is on
	Output Phase Loss Protection (OPL)	If the OPL function acts, the motor stops rotation automatically
Environment Specification	Location	Indoor (protected from corrosive gases and dust)
	Ambient Temperature	-10 ~ +40°C (IP20/NEMA1 and IP55/NEMA12), -10 ~ +50°C (IP00), with de-rating, its maximum operation temperature is 60°C
	Storage Temperature	-20 ~ +70°C
	Humidity	95%RH or less ( no condensation )
Altitude and Vibration	Altitude of 1000 meters or lower, 1.0G, in compliance with IEC 60068-2-6	
Communication Function	Built-in RS-485 as standard (Modbus protocol with RJ45 / BACnet / Metasys N2)	
PLC Function	Built-in	
Electromagnetic Interference (EMI)	Meet EN61800-3 Standard, IP20 400V 75HP or below and IP55 400V 60HP can be built in	
Electromagnetic Susceptibility (EMS)	Meet EN61800-3 Standard	
Certification	CE	Meet EN61800-3(CE & RE) and EN61800-5-1(LVD)
	UL	UL508C
Option Card	1 to 8 Pump card, HOA LCD keypad, Profibus card	

### Notes :

- Speed control accuracy will be influenced when the motor and installation condition are different.
- The default setting of carrier frequency is different from models.

# WIRING DIAGRAM

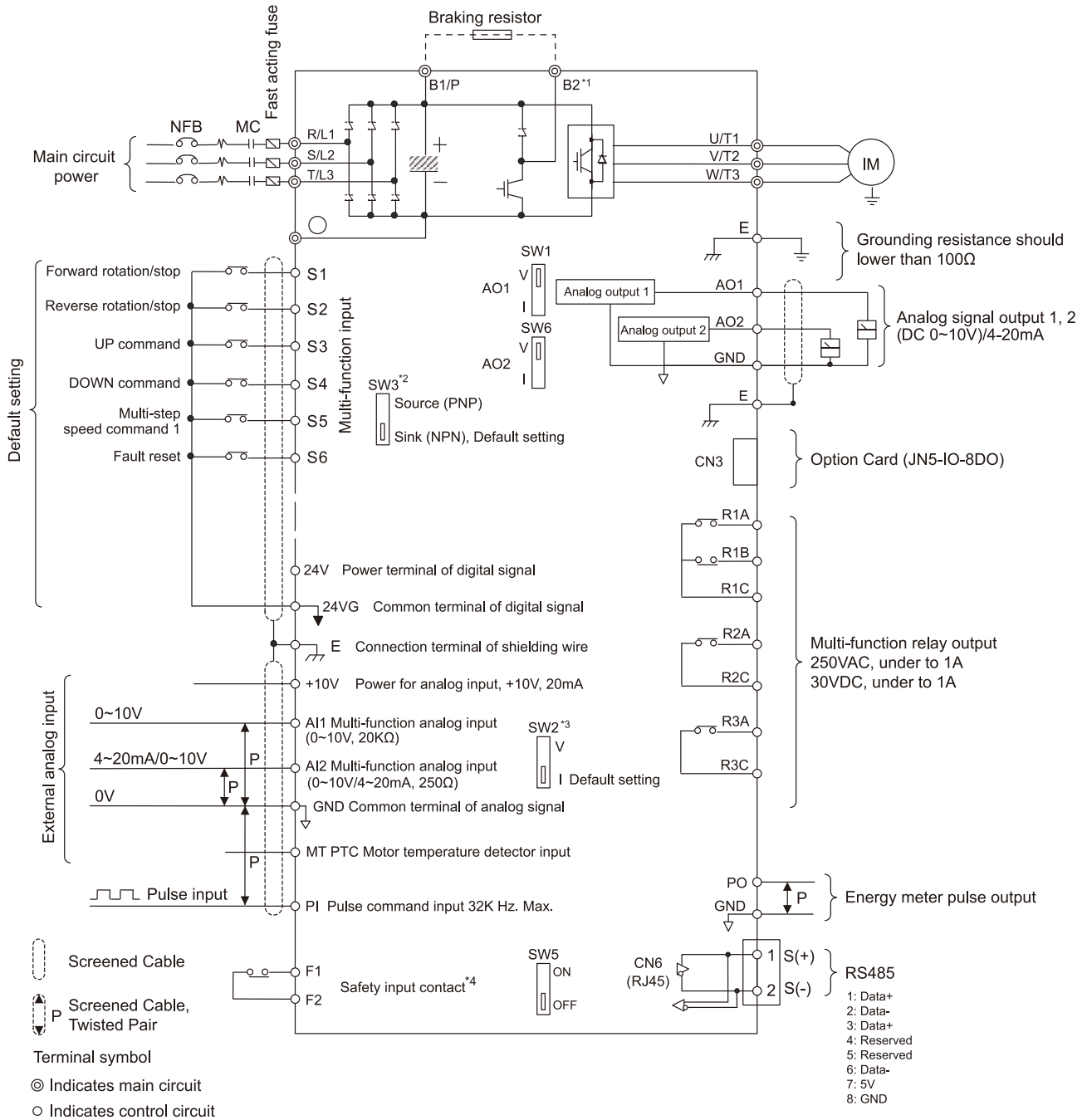

## DIMENSIONS

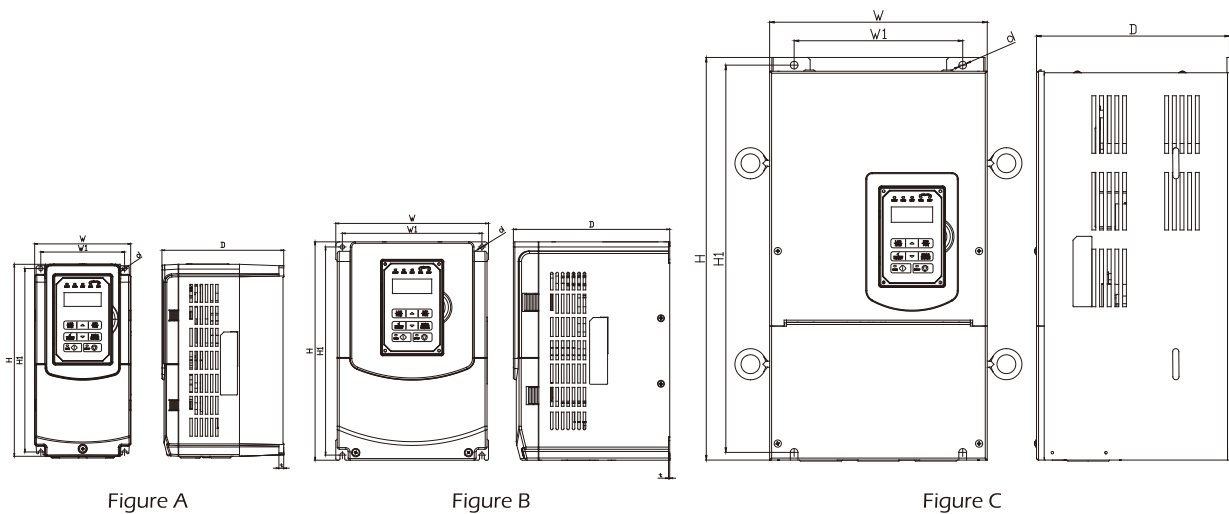

Figure	Enclosure	Frame	Models	Dimensions(mm)							Weight (kg)
				W	H	D	W1	H1	t	d	
A	IP20	Frame2	F510-2005-H3	140	279	177	122	267	7	M6	3.8
			F510-2008-H3								
			F510-4005-H3								
			F510-4008-H3								
			F510-4010-H3								
B	IP20	Frame 3	F510-2010-H3	210	300	215	192	286	1.6	M6	6.2
			F510-2015-H3								
			F510-4015-H3								
			F510-4020-H3								
		Frame 4	F510-2020-H3	265	360	225	245	340	1.6	M8	10
			F510-2025-H3								
			F510-2030-H3								
			F510-4025-H3								
C	IP20	Frame 5	F510-2040-H3	284	525	252	220	505	1.6	M8	30
			F510-2050-H3								
			F510-4050-H3								
			F510-4060-H3								
			F510-4075-H3								

## DIMENSIONS

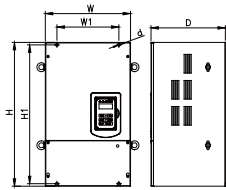

Figure D

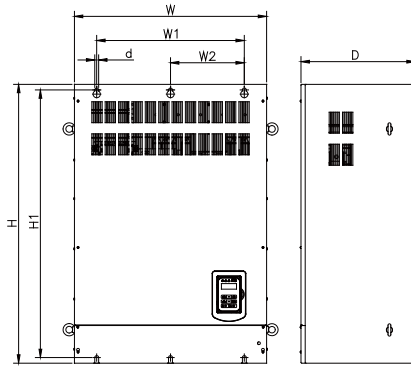

Figure E

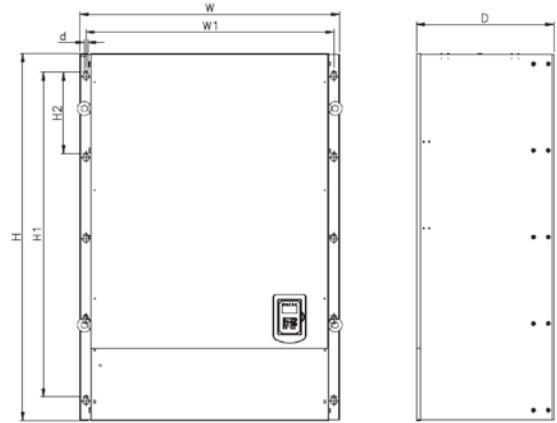

Figure F

Figure	Enclosure	Frame	Models	Dimensions(mm)									Weight (kg)
				W	H	D	W1	W2	H1	H2	t	d	
D	IP00	Frame 6	F510-2060-H3	344	580	300	250	N/A	560	N/A	1.6	M10	40.5
			F510-2075-H3										
			F510-4100-H3										
			F510-4125-H3										
		Frame 7	F510-2100-H3	459	790	324.5	320	N/A	760	N/A	1.6	M10	74
			F510-2125-H3										
E	IP00	Frame 8	F510-2150-H3	690	1000	410	530	265	960	N/A	1.6	M12	184
			F510-2175-H3										
			F510-4300-H3										
			F510-4375-H3										
			F510-4425-H3										
F	IP00	Frame 9	F510-4535-H3	960	1356	507	916	N/A	1200	300	3	M12	340
			F510-4670-H3										
			F510-4800-H3										



## DIMENSIONS

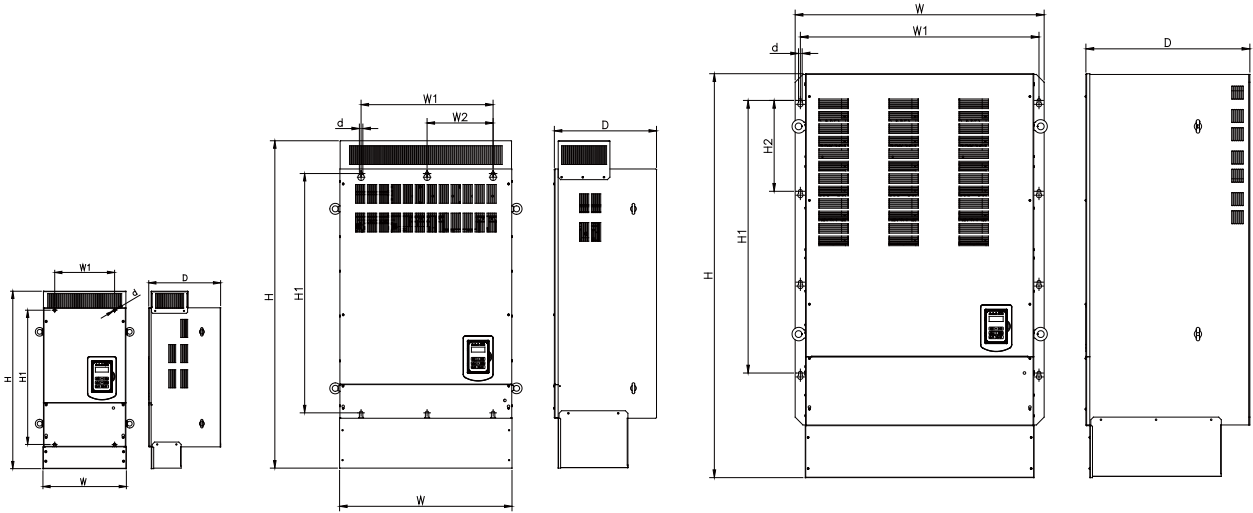

Figure G

Figure H

Figure I

Figure	Enclosure	Frame	Models	Dimensions(mm)									Weight (kg)		
				W	H	D	W1	W2	H1	H2	t	d			
G	IP20	Frame 6	F510-2060-H3	348.5	740	300	250	N/A	560	N/A	1.6	M10	44		
			F510-2075-H3												
			F510-4100-H3												
			F510-4125-H3												
		Frame 7	F510-2100-H3	463.5	1105	324.5	320	N/A	760	N/A	1.6	M10	81		
			F510-2125-H3												
			F510-4150-H3												
H	IP20	Frame 8	F510-4175-H3	690	1313	410	530	265	960	N/A	1.6	M12	194		
			F510-4215-H3												
			F510-4250-H3												
			F510-2150-H3												
			F510-2175-H3												
I	IP20	Frame 9	F510-4300-H3	960	1556	507	916	N/A	1200	300	3	M12	330		
			F510-4375-H3												
			F510-4425-H3												
			F510-4535-H3											340	
			F510-4670-H3												
			F510-4800-H3												

\*The enclosure type of IP00 model is standard for frame 6 to frame 9. It is required to purchase the installation accessories if user selects the enclosure type of IP20 model.

Frame 6 JN5-NK-A06

Frame 7 JN5-NK-A07

Frame 8 JN5-NK-A08

Frame 9 JN5-NK-A09

## DIMENSIONS

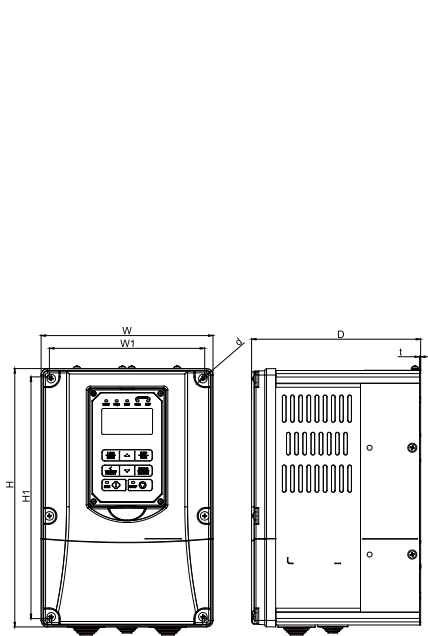

Figure J

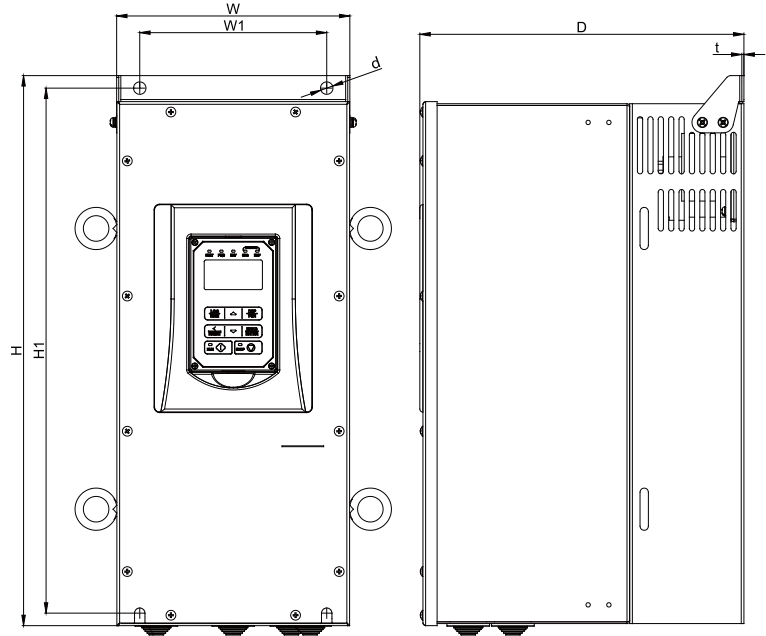
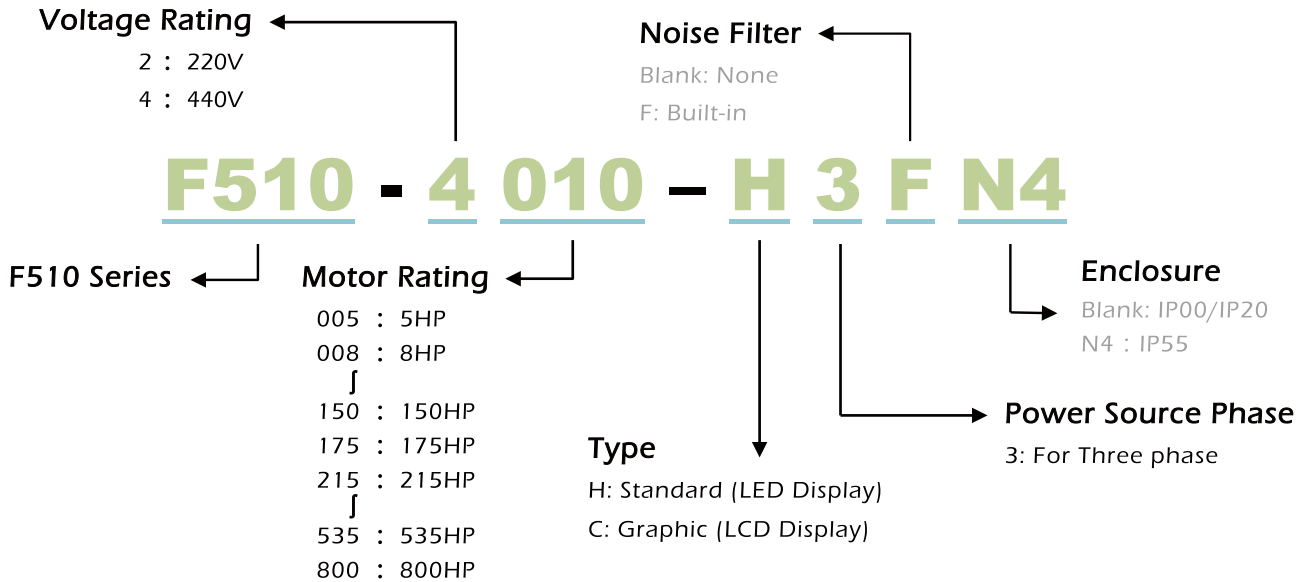

Figure K

Figure	Enclosure	Frame	Models	Dimensions(mm)							Weight (kg)	
				W	H	D	W1	H1	t	d		
J	IP55(NEMA12)	Frame 1	F510-4005-C3FN4	189	284	186	171	266	1.2	M5	7	
			F510-4008-C3FN4									
		Frame 2	F510-4010-C3FN4	230	320	210	210	305	2	M5	10.5	
F510-4015-C3FN4												
Frame 3		F510-4020-C3FN4	265	396	227	249	380	2	M5	17		
		F510-4025-C3FN4										
K			Frame 4	F510-4030-C3FN4								
				F510-4040-C3FN4	224	527	311	180	505	2	M10	32.5
			F510-4050-C3FN4									
	Frame 5		F510-4060-C3FN4									
			F510-4075-C3N4	326	695	343	276	671	2.3	M10	55	
F510-4100-C3N4												

Note: Models for 4075&4100 are not built-in filter.

## MODEL DESIGNATION



## ACCESSORIES

Accessories	Description	Model	Note
Cables	IP20 Digital operator extention cable	JN5-CB-01M	1 meter
		JN5-CB-02M	2 meter
		JN5-CB-03M	3 meter
		JN5-CB-04M	4 meter
		JN5-CB-05M	5 meter
	RJ45 to USB connecting cable	JN5-CM-USB	1.8 meter
		JN5-CM-USB-3	3 meter
Communication Card	Profibus option card	JN5-CM-PBUS	Under development
Communication Moduels (Gateways)	Profibus DP module	JN5-CM-PDP	
	TCP-IP module	JN5-CM-TCPIP	
	DeviceNet module	JN5-CM-DNET	
	CANopen module	JN5-CM-CAN	
NEMA1 Kits	Mechanical device consisting of anti-dust cover on the upper part and wiring box on the bottom to meet NEMA1	JN5-NK-A06	Frame6
		JN5-NK-A07	Frame7
		JN5-NK-A08	Frame8
Digital Operators	IP20 LED Type	JN5-OP-F01	
	IP20 LCD Type	JN5-OP-F02	
	IP20 LCD HOA Type	JN5-OP-F03	With HAND/OFF/AUTO function
	IP20 Blank type	JN5-OP-A03	
	IP55 LCD Type	JN5-OP-F04	
Others	1 to 8 Pump card	JN5-IO-8DO	
	F510 remote control box	JNEP-16-F	
	Copy Module for 510 series	JN5-CU	



Ideal For Fan & Pump

Distributor

**TECO**  
**TECO ELECTRIC & MACHINERY CO., LTD.**

10F, No. 3-1, Park St., Nan-Kang, Taipei 115, Taiwan

TEL : 886-2-6615-9111Ext.1766

FAX : 886-2-6615-1033

<http://globalsa.teco.com.tw>

Specifications covered in this brochure may be subject to change without notice.



GJ-68-03 2014-05-20